

**UNIFIED SIGNAL CONVERTERS
E875A, E875B, E875C, E875E**

Operation manual

49501860.3.0001 PЭ

Contents

- 1 Description and operation 3
 - 1.1 General Information 3
 - 1.2 Characteristics 4
 - 1.3 Construction 7
 - 1.4 Functional description 7
 - 1.5 Marking and sealing 10
 - 1.6 Packing 10
- 2 Uses to assignment 11
 - 2.1 Operational constraints 11
 - 2.2 Preparation for use 11
 - 2.3 Use 11
 - 2.4 Operation in extreme conditions 12
- 3 Maintenance and repair 12
 - 3.1 Safety 12
 - 3.2 Order of maintenance 12
 - 3.3 Metrology monitoring 13
- 4 Storage 13
- 5 Transportation 13
- Annex A. General Form of the converter 14
- Annex B. Variants of converter mounting 15
- Annex C. Diagrams of converter connections 16



WARNING! CONVERTER HAS A SAFETY SYMBOL SHOWING THAT SPECIFIC WARNING OR CAUTION INFORMATION IS GIVEN IN A MANUAL, TO AVOID PERSONAL INJURY OR EQUIPMENT DAMAGE.

This operation manual contains information for using and operating Unified Signal Converters E875A, E875B, E875C, E875E (further - Converters) and information on packing, transportation and storage.

Read this manual before operation.

1 Description and operation

1.1 General Information

Converters are intended for converting a DC-current unified input signals to DC-current unified output signals and can be applied to monitoring currents of electrical systems, in the equipment of technical diagnostics, for an integrated automation of plants of power engineering and different industries.

Converters correspond to engineering factors TY 4218-005-49501860-99.

The converters are produced with type's outputs:

- A - output current (0 - 5) mA;
- B - output current (4 - 20) mA;
- C - output current (0 -20) mA;
- E - output current (minus 5 - 0 - 5) mA.

The following variants are produced:

- with two similar outputs;
- with three similar outputs;
- with two or three dissimilar outputs.

Converters are mounted on the rails TH-35 ГООТ Р МЭК 60715-2003 or immediately on the panel.

Power Supply: 220 V(+10%; -15%); 50Hz.

The converters are hardware SSI products of the third order according to ГООТ 12997-84.

Guard level IP00 (GOST 14254-96, IEC 529-89).

Vibration and Shock (ГООТ 12997-84):

- Group N1 – at mounting on the rail (vibration in a frequency band from 10 up to 55 Hz with a displacement amplitude 0,15 mm).

Operating Environment: Group C4 (ГООТ12997-84):

- Ambient Air Temperature - 30 to 50 °C;
- Relative Humidity at 35 °C up to 95 %;
- Atmospheric pressure, kPa (mm Hg) 84-106 (630-800).

Climatic category YXJ3 (ГООТ 15150-69).

Standard conditions for use:

- Ambient Air Temperature 20±5 °C;
- Relative Humidity, 30 to 80 %;
- Atmosphere pressure, kPa (mm Hg) 84-106 (630-800);
- Power Supply 220 ± 4,4 V.

Example of a designation of the converter with similar outputs:

Converter E 8 7 5 A B 2 TY 4218-001-49501860-99

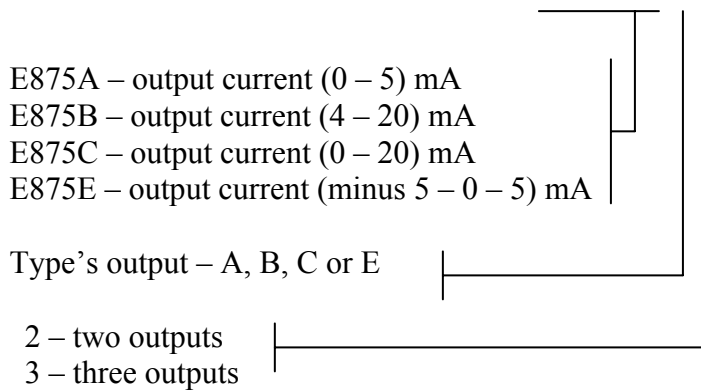

Example of a designation of the converter with dissimilar outputs:

Converter E 8 7 5 A A B C TY 4218-001-49501860-99.

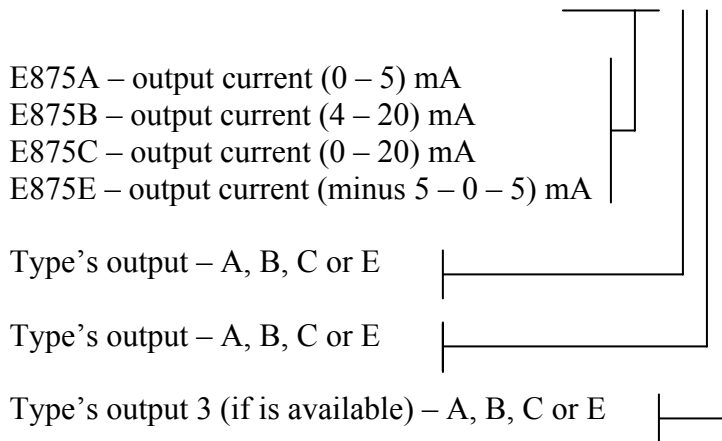

1.2 Characteristics

1.2.1 Converter converts direct current input signal to direct current output signal according to tables 1, 2.

The nominal converting function is linear, according to the formula:

$$I_{OUT} = I_{OUTMIN} + \frac{I_{OUTMAX} - I_{OUTMIN}}{I_{INMAX} - I_{INMIN}} \cdot (I_{IN} - I_{INMIN}), \quad (1)$$

where: I_{OUT} - the value of the output current;

I_{IN} - the value of the input current;

I_{OUTMIN} , I_{OUTMAX} - initial and finite values of the output current;

I_{INMIN} , I_{INMAX} - initial and finite values of the input current.

The converting subfunction is nonlinear for E875A, E875B, and E875C with types outputs A, B, C, according to the formula:

$$I_{OUT} = I_{OUTMIN} + (I_{OUTMAX} - I_{OUTMIN}) \cdot \sqrt{\frac{I_{IN} - I_{INMIN}}{I_{INMAX} - I_{INMIN}}} \quad (2)$$

Table 1

Type's modification	Input DC range, mA	Input resistance, Ω (max)	Output 1	Output 2	Output 3	Note
E875Ax2	0 - 5	500	x	x		Similar outputs
E875Ax3			x	x	x	
E875Axx			x	x		Dissimilar outputs
E875Axxx			x	x	x	
E875Bx2	4 - 20	150	x	x		Similar outputs
E875Bx3			x	x	x	
E875Bxx			x	x		Dissimilar outputs
E875Bxxx			x	x	x	
E875Cx2	0 - 20	150	x	x		Similar outputs
E875Cx3			x	x	x	
E875Cxx			x	x		Dissimilar outputs
E875Cxxx			x	x	x	
E875Ex2	-5 - 0 - 5	500	x	x		Similar outputs
E875Ex3			x	x	x	
E875Exx			x	x		Dissimilar outputs
E875Exxx			x	x	x	
Note –Symbol «x» may accept A, B, C, E values						

Table 2

Type's output	Output DC range, mA	Load resistance range, Ω
A	0 - 5	0 - 3000
B	4 - 20	0 - 500
C	0 - 20	0 - 500
E	Minus 5 - 0 - 5	0 - 3000

1.2.2 For linear converting function (in accordance with formula 1), limits of intrinsic error are:
- for E875B, E875C with types outputs B, C: $\pm 0,25$ % of the fiducial value;
- for E875B, E875C with types outputs A, E and E875A, E875E: $\pm 0,5$ % of the fiducial value.
The finite value of output DC range is taken as a fiducial value.

For nonlinear converting function (in accordance with formula 2), limits of intrinsic error are $\pm 0,5$ % of the fiducial value. The finite value of input DC range is taken as a fiducial value.

1.2.3 Variations from influencing magnitudes correspond to table 3.

Table 3

Name of influencing magnitude	Value of influencing magnitude	Variation, % of the fiducial value
Ambient Air Temperature	- 30 to 50 °C	±0,4 on 10 °C of temperature variation
Relative Humidity	to 95% at 35 °C	± 0,5
External magnetic field of frequency 45-65 Hz by strength	to 400 A/m	±0,5

1.2.4 Setup time of performance is 30 min.

1.2.5 Setting time of output signal is 0,5 s.

1.2.6 Pulsation amplitude 0,25 %.

1.2.7 The intrinsic error corresponds:

- On expiring a setup time of performance; (Instability for 24 hour no more than 0,1 %);
- At grounding one of output contacts;
- After effecting sine-wave vibrations in a frequency band from 10 up to 55 Hz with displacement amplitude 0,15 mm.

1.2.8 Converters withstand 150% overload by an input signal.

The output current, when overloading, is no more:

- for types outputs A and E: 5,5 mA;
- for types outputs b and C: 21 mA.

1.2.9 Converters withstand a long-lived break of a load circuit without failures. An output voltage at a break of a load circuit is no more than 30 V.

1.2.10 Isolation (between an input and power supply, between an output and power supply) withstands a testing voltage of practically sine-wave shape by frequency from 45 up to 65 Hz during 1 min:

- 2,5 kV RMS- in standard conditions;
- 1,5 kV RMS - to 95% R.H. at 35°C.

1.2.11 Isolation (between an input and output, between different outputs) withstands a testing voltage of practically sine-wave shape by frequency from 45 up to 65 Hz during 1 min:

- 0,5 kV RMS - in standard conditions;
- 0,3 kV RMS - to 95% R.H. at 35°C.

1.2.12 Electrical insulation resistance of circuits pointed in 1.2.10, 1.2.11 is not less

- 40 MΩ - in standard conditions;
- 10 MΩ - to 80% R.H. at 50°C;
- 2 MΩ - to 95% R.H. at 35°C.

1.2.13 Input Power Consumption is less than:

- E875A, E875E..... 12,5 mW;
- E875B, E875C..... 60 mW.

1.2.14 Power Supply Consumption is less than:

- for converters with5 V·A

1.2.15 Overall dimensions... 120x80x120 mm

1.2.16 Weight 0,7 kg

1.3 Construction

1.3.1 General Form of the converter can be seen in Annex A.

1.3.2 Converter has the following parts:

- Case;
- Cover;
- Switching board;
- Component board;
- Supply transformer;
- Latch.

1.3.3 The contacts, established on a cover, ensure strengthening a component board and reliable contact of conductors of a plated circuit to bringing wires.

The electrical connection of the component board with a switching board is yielded by the soldering. Inside a case the component board is arrested by guide ridge.

The cover is mounted to a case through four screws, which can be sealed up.

The latch ensures mounting the converter to the rail or panel depending on variant of installation.

1.4 Functional description

The converter is a device with digital processing of a signal.

Converter Block Diagram can be seen in Figure 1.

Master units are an input unit and two (or three) identical output units. The galvanic isolation is ensured with optrons and supply from separate secondary windings of the supply transformer.

The input unit is an analog-digital converter (ADC) implementing function of sigma - delta transformation.

The fundamental clusters of ADC analog part are: an integrator; a gated analog comparator (included into the composition of a microcontroller); an analog switch SW1 (the CMOS-structure of microcontroller's output port executes its function). The average on-off time ratio of pulses on an output of the comparator is proportional to an input current of the converter.

The fundamental clusters of ADC digital part of an input cascade are: software implemented digital filter LPF; decimator D; parallel-to-series conversion (P/S).

The codes N_H and N_L arrive at the input LPF synchronously with switching the switch SW1. If time constant of the filter is much greater than a period of a gating T_c , the output code LPF is defined by expression

$$N_F = N_L + Q_S \cdot (N_H - N_L),$$

where: Q_S – average on-off time ratio of pulses on comparator output during measurement.

The output code on LPF output is proportional to Q_S also to input current of the converter. The coefficients N_H and N_L are erected so that the output code N_F received values:

$$N_F = 0 \quad \text{for an initial value of variation of an input current range;}$$

$$N_F = 2^{11} - 1 \quad \text{for a finite value of variation of an input current range.}$$

The output code of the filter arrives to the decimator D. The code accumulates and averages particular quantity of the values, which have arrived at its input:

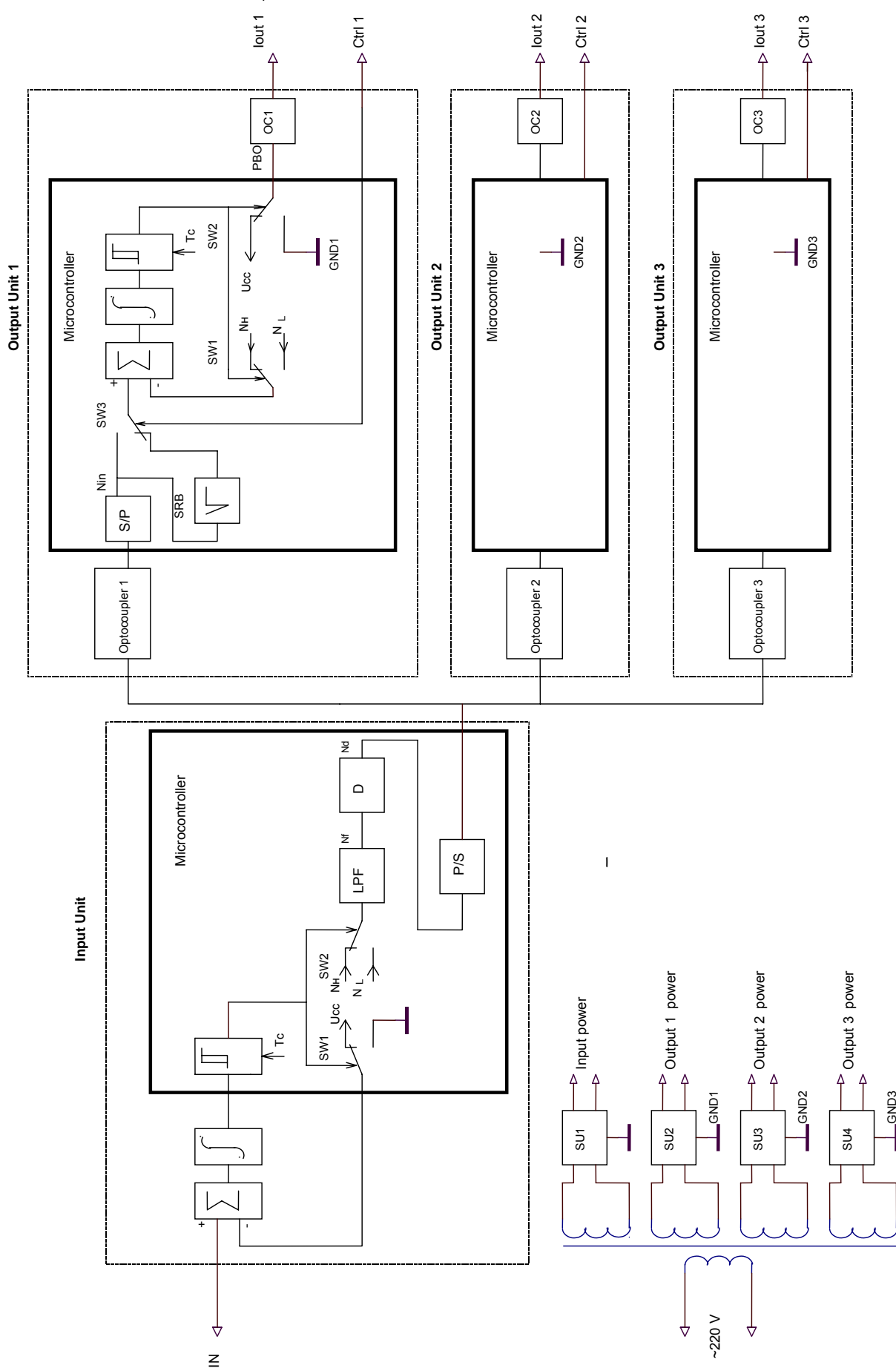

Figure 1. Block Diagram

$$N_d = - \frac{\sum_{i=0}^{K_d} N_{Fi}}{K_d}$$

The number of accumulated values K_d is selected by such, that following condition was executed:

$$K_d \cdot T_c = 1/50 \quad [1/\text{Hz}],$$

Thus the supply frequency and its harmonics are eliminated from the output signal of a decimator. The signal from an output decimator D is converted to a serial code and transited through optocouplers to output stages of the converter.

The output unit is DAC, which is carried out by a principle of a sigma - delta transformation. It implements function of ADC of an input cascade backward.

Each output stage can work in linear ($I_{out} \sim I_{in}$) and in nonlinear ($I_{out} \sim \sqrt{I_{in}}$) modes. The choice of a mode is defined by absence or presence a jumper on the relevant controlling input of the converter.

DAC-digital part of an output unit is implemented on a microcontroller and includes the following clusters: the series- to- parallel conversion (S/P); the block of rootsquaring SRB (activate at presence a jumper on the controlling input); the adder; the integrator; the comparator.

DAC-analog part includes: CMOS-structure of an output port of a microcontroller; matching output cascade (OC) realized by operational amplifier. The matching cascade ensures flattening and linear transforming of a voltage U_{PBO} on an output of the microcontroller to converter's output current, that is

$$I_{out} \sim \frac{1}{T_{meas}} \int_0^{T_{meas}} U_{PBO} dt,$$

where: T_{meas} – measuring time.

The on-off time ratio of pulses on the comparator output and consequently on an output PBO of a microcontroller is featured by expression:

$$N_{in} = QN_H + (1-Q)N_L,$$

or

$$Q = \frac{N_{in} - N_L}{N_H - N_L}.$$

The mean of voltage on output PBO is proportional to on-off time ratio of pulses Q_s :

$$U_{PBO} = U_c \cdot Q_s,$$

where: U_c – supply voltage of a microcontroller.

The expression for an output current has an aspect:

$$I_{out} \sim \frac{U_c}{T_{meas}} \int_0^{T_{meas}} [(N_{in} - N_L) / (N_H - N_L)] dt.$$

The coefficients N_H and N_L are erected so that the value of an output current of the converter was equaled:

- initial value of a range if $N_{in} = 0$;
- finite value of a range if $N_{in} = 2^{11} - 1$.

The precision circuits are applied to stabilize a supply voltage of microcontrollers' input and output stages of the converter.

The tuning of the converter is carried on by an electronic mode through a technological connector.

1.5 Marking and sealing

1.5.1 The following information is marked on a cover of the converter:

- The name and type designation;
- Manufacturer's mark;
- The nominal value of auxiliary supply voltage and nominal value of auxiliary supply frequency;
- Maximal value of power supply (VA);
- Input and output signals rated;
- Unit symbol of input and output signals;
- Overvoltage category;
- Load resistance range;
- Module of intrinsic error;
- The table of connections;
- Designation of numbers and polarity of terminal;
- Symbol  ;
- Serial number and two last digits of Issue Year.

1.5.2 Sealing of the converter is yielded with a bitumen mastic №1 (according to GOST 18680-73) applies on one of four located on a cover screws.

1.6 Packing

1.6.1 The converters are delivered in transport container.

1.6.2 In transport container there is:

- Operation manual (1 copy for set of 50 converters or on separate delivering);
- Packing leaf.

1.6.3 The converter is packaged into individual packing.

The passport is inserted inside the individual packing.

2 Uses to assignment

2.1 Operational constraints

2.1.1 The converters are not intended for operation in requirements explosion-hazard and hostile environment.

2.1.2 The converters must not be effected by direct heat up to temperature more 50°C. The converters should be placed on the premises without sharp temperature fluctuation and off the sources of strong electromagnetic field.

2.2 Preparation for use

2.2.1 Check integrity of packing after deriving the converter. Unpack it. Take out the converter, make exterior survey, get sure that any apparent mechanical damages are missing. Check completeness of delivering according to table 4.

Table 4

Name and nomenclature	Quantity
Converter	1
Unified Signal Converters E875A, E875B, E875C, E875E. Passport	1
Unified Signal Converters E875A, E875B, E875C, E875E. Operation manual	1*
Individual package	1
Latch	1**
* On a batch in quantity 50 pieces, delivered at the one address	
** Set on the case	

2.2.2 Check the information on a cover of the converter on correspondence to required parameters.

2.3 Use

2.3.1 All operations on mounting and maintenance should be making with observance of live rules on provision of safe service.

2.3.2 Make arranging a place of mounting of the transducer on plant according to an Annex B.



WARNING!
THE AUTOMATIC SWITCH OR THE SWITCH PLACED IN IMMEDIATE PROXIMITY FROM THE TRANSDUCER SHOULD BE INCLUDED IN INSTALLATION OF BUILDING WIRING. THE SWITCH SHOULD BE MARKED AS SWITCHING-OFF DEVICE FOR THE TRANSDUCER.

2.3.3 Installation of the converter on plant

2.3.3.1 When mounting the converter *on the rail*:

- place a latch according to figure B.1 to link the protuberances of a case to edge of the rail;
- push a case up to its fixing.

The mounting of the converter on the rail is supposed at mount the rail on a horizontal or vertical plane.

When the rail is mounted on the vertical plane, its distortion from a horizontal position should not be more than 15°.

2.3.3.2 When mounting the converter *on the panel*:

- fix a latch on the panel with the help of two screws according to figure B.2;
- pull the converter over a latch against the stop.

Use two screws with a diameter 4 mm to fasten a latch on the panel. Screws should not overhang a mounting plane of the latch.

When mounting the converter on a latch it is necessary to provide on object a place not less than 15 mm for initial fixing of the converter.

2.3.4 Fix exterior conductive wires on contacts according to the table of connections, which is located on a cover of the converter.

2.3.5 Install an exterior jumper on the relevant controlling input for use of nonlinear function of converting.

2.3.6 Verify the correspondence of output parameters of a radiant of a signal to data-ins of the converter. Verify quality of wiring.

2.3.7 Turn on supply voltage 220 V on the converter.

2.3.8 Turn on an input signal on the converter.

2.4 Operation in extreme conditions

2.4.1 You should turn out the converter immediately in case of originating an emergency condition of operation.

The switch or automatic switch should be used for cutting off.



3 Maintenance and repair

3.1 Safety

3.1.1 The qualified personnel should execute operations of maintenance.

3.1.2 The transducers correspond to ГОСТ P 52319-2005 (IEC 61010-1:2001).

Insulation class is primary. Pollution degree is 2. Overvoltage category III.

3.1.3 IT IS FORBIDDEN: TO CHANGE EXTERNAL CONNECTIONS, WHEN INPUT SIGNAL AND SUPPLY VOLTAGE ARE AVAILABLE IN THE CONVERTER.



3.2 Order of maintenance

3.2.1 It is recommended quarterly to carry out routine inspection in field. For this purpose:

- to turn input signal and supply voltage off;
- to delete from a case a dust;

- to test a condition of a case; to be convinced of absence of mechanical failures; to test a condition of strengthening;

- to turn on a supply voltage and input signal on the converter after the termination of survey.

3.2.2 If the converter is mounted on the rails you can carry demounting by release of a latch by a screwdriver inserted into a recess in the bottom of the case.

3.3 Metrology monitoring

3.3.1 To confirm real values of the metrology characteristics and fitness of the converter to application, they can be exposed to calibration according to the document 49501860.3.0001 МП «Преобразователи электрических унифицированных сигналов E875A, E875B, E875C, E875E. Методика поверки» («Unified Signal Converters E875A, E875B, E875C, E875E. Calibration procedure»), which was matched with ВНИИМС (All-Russian Research Institute).

The converter should be calibrated on a 1-year interval determined by the requirements of this document.

4 Storage

4.1 Before introduction in operation the converters should be stored in storehouses according to ГОСТ 12997-84.

4.2 Storage conditions for converters in transport container:

- Ambient Air Temperature..... 5 to 50 °C;

- Relative Humidity at 25 °C up to 80 %;

4.3 Storage conditions for converters in individual packing:

- Ambient Air Temperature..... 10 to 35 °C;

- Relative Humidity at 25 °C up to 80 %;

4.4 The contents of a dust, steams of acids and alkalis, aggressive gases and other harmful admixtures calling corrosion should not exceed the contents of the corrosion-active agents for the atmosphere of type 1 (ГОСТ 15150-69).

5 Transportation

5.1 The converters in transport container can be transported in the closed vehicles of any type.

When air transportation the converters should be disposed in heated hermetic bays.

5.2 Values of climatic and mechanical effects on the converter at transportation should be in limits:

- Ambient Air Temperature..... - 50 to 50 °C;

- Relative Humidity at 35 °C up to 95 %;

- Atmospheric pressure, kPa (mm Hg)..... 84-106 (630-800).

- Impacts with peak shock acceleration 98 m/sec².

**Annex A
(informative)
General form of the converter**

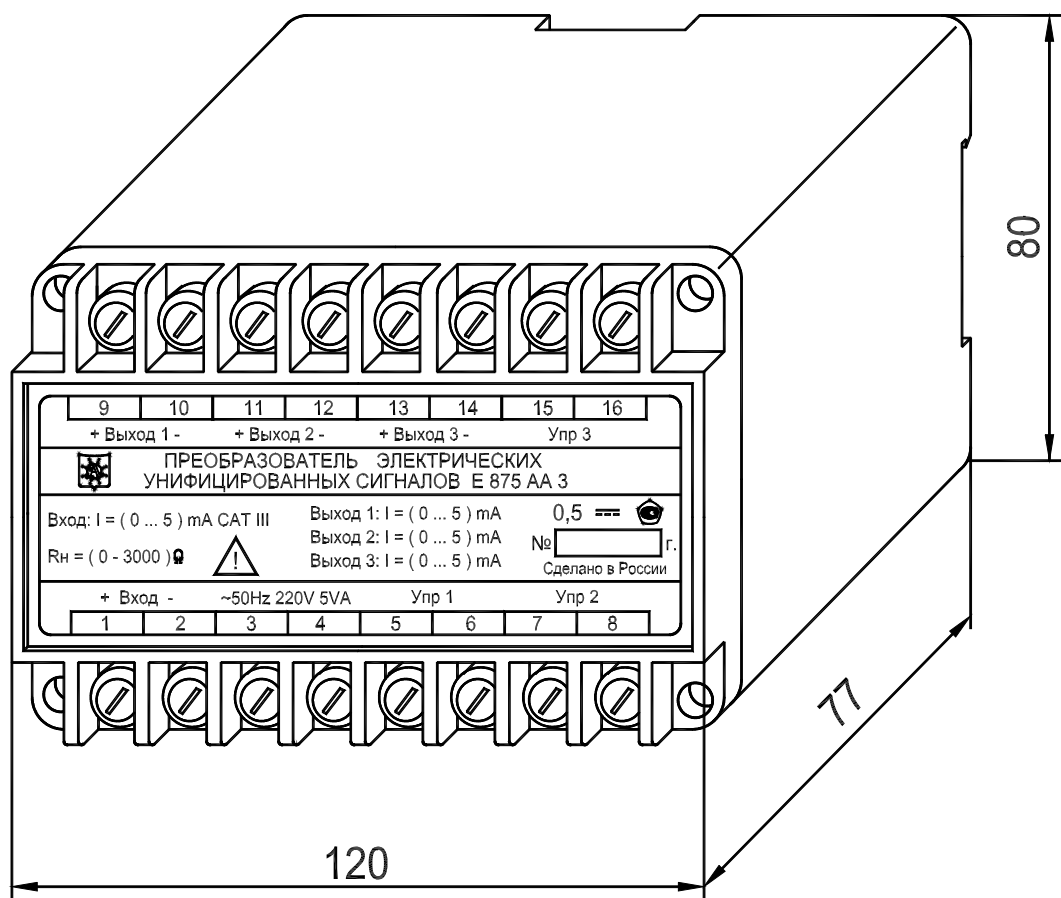

Figure A.1

Annex B
(informative)
Variants of converter mounting

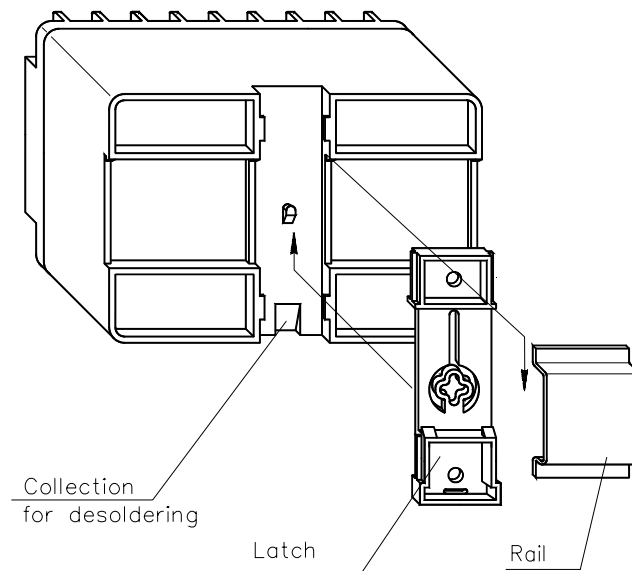

Figure B.1 Mounting on the Rail

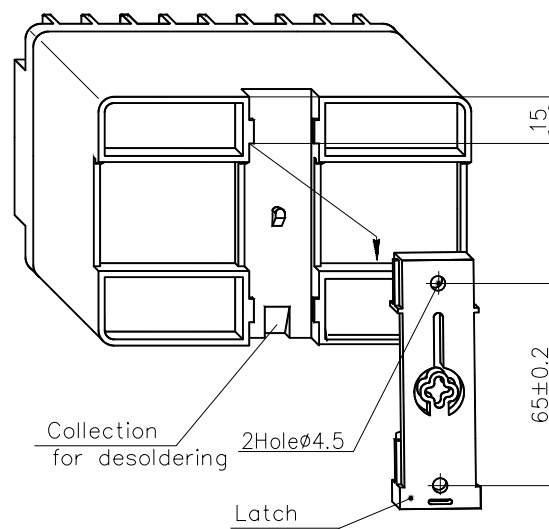
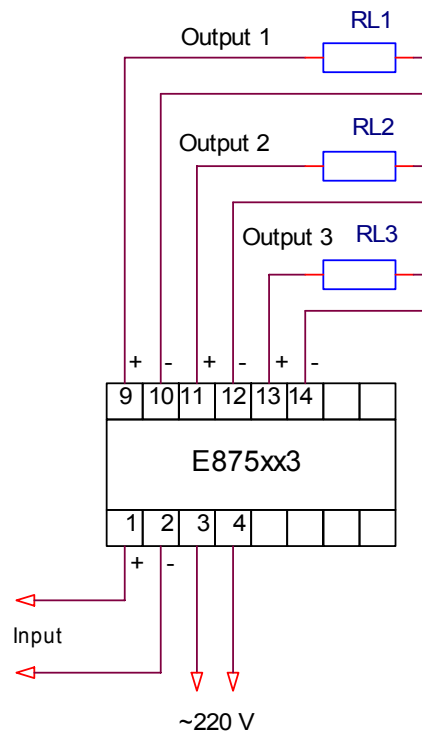
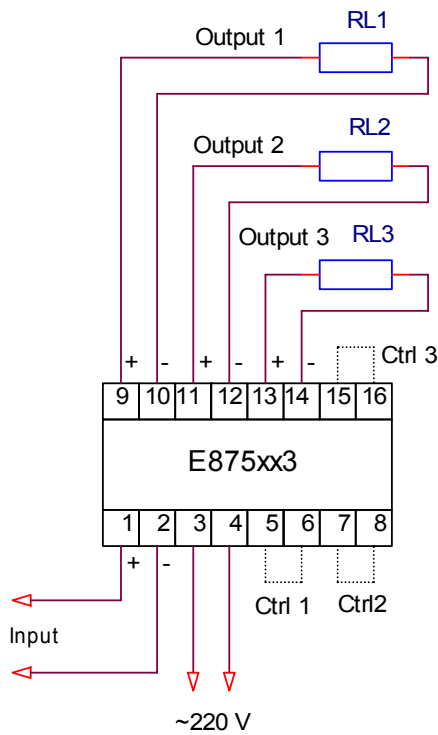

Figure B.2 Mounting on the Panel

Annex C (informative) Diagrams of converters connections



a) E875AA3, E875AB3, E875AC3
E875BA3, E875BB3, E875BC3,
E875CA3, E875CB3, E875CC

b) E875AE3, E875BE3, E875CE3,
E875EA3, E875EB3, E875EC3, E875EE3

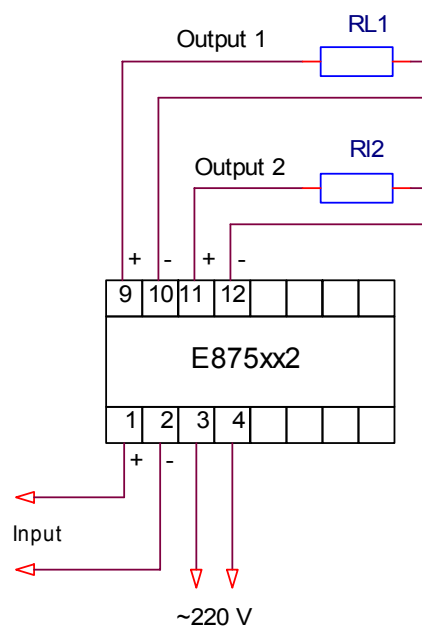
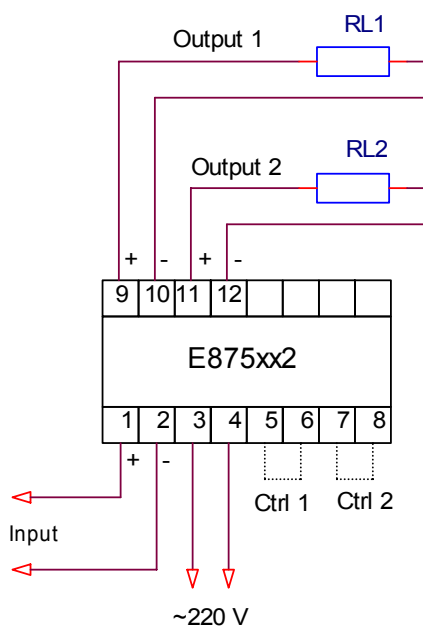

c) E875AA2, E875AB2, E875AC2
E875BA2, E875BB2, E875BC2,
E875CA2, E875CB2, E875CC2

d) E875AE2, E875BE2, E875CE2,
E875EA2, E875EB2, E875EC2, E875EE2

Figure C.1