

**DIRECT CURRENT
MEASURING TRANSDUCERS
E856A, E856B, E856C,
E856AP, E856BP, E856CP, E856EP**

Operation manual

49501860.3.0004 P3

Contents

1 Description and operation	3
1.1 General Information	3
1.2 Characteristics	4
1.3 Construction	6
1.4 Functional description	6
1.5 Marking and sealing	9
1.6 Packing	9
2 Uses to assignment	10
2.1 Operational constraints	10
2.2 Preparation for use	10
2.3 Use	10
2.4 Operation in extreme conditions	11
3 Maintenance and repair	12
3.1 Generalities	12
3.2 Safety	12
3.3 Order of maintenance	12
3.4 Metrology monitoring	12
4 Storage	13
5 Transportation	13
Annex A. General Form of the transducer	14
Annex B. Variants of transducer mounting	15
Annex C. Diagram of transducer connections	16

This operation manual contains information for using and operating Direct Current Measuring Transducers E856A, E856B, E856C, E856AP, E856BP, E856CP, E856EP (further - Transducers) and information on packing, transportation and storage.

Read this manual before operation.

1 Description and operation

1.1 General Information

Transducers are intended for connection through the external shunt with 75 mV rated voltage.

Transducers provide with a linear converting from direct current input signals to one or two direct current unified output signals.

Transducers can be applied in the equipment of technical diagnostics, for an integrated automation of plants of power engineering and different industries or to DC monitoring.

Transducers correspond to engineering factors TY 4227-004-49501860-99.

Transducers are mounted on the rails TH-35 ГОСТ Р МЭК 60715-2003 or immediately on the panel.

Transducers are produced with Power Supply from alternating current network with voltage 220 V and frequency 50 Hz.

Depending on quantity of output the transducers are produced of two variants:

- with one output;
- with two outputs.

Transducers are produced without galvanic link between input and output circuits also between different outputs.

The transducers are hardware SSI products of the third order according to ГОСТ 12997-84.

Operating Environment: Group C4 (ГОСТ 12997-84):

- Ambient Air Temperature - 30 to 50 °C;
- Relative Humidity at 35 °C up to 95 %;
- Atmosphere pressure 84-106 kPa (630-800 mm Hg).

Climatic category: YXJ3 (ГОСТ 15150-69).

Standard conditions for use:

- Ambient Air Temperature 20±5 °C;
- Relative Humidity, 30 to 80 %;
- Atmosphere pressure 84-106 kPa (630-800 mm Hg);
- Power Supply 220 ± 4,4 V.

Guard level: IP00 (ГОСТ 14254-96, МЭК 529-89).

1.2 Characteristics

1.2.1 Transducer converts input signal, namely direct voltage from a shunt, to direct current output signals according to table 1.

Supposed value of input ripple factor is 100% when frequency of the variable component is from 45 up to 1000 Hz.

Table 1

Type's modification	Input DC voltage from the shunt, mV	Output DC range, mA	Load resistance range, Ω
E856A1 E856A2	0 - 75	0 - 5	0 - <u>2000 - 3000</u>
E856B1 E856B2		4 - 20	0 - <u>200 - 300</u> - 500
E856C1 E856C2		0 - 20	0 - <u>200 - 300</u> - 500
E856AP1 E856AP2	minus 75 - 0 - 75	0 - 2,5 - 5,0	0 - <u>2000 - 3000</u>
E856BP1 E856BP2		4 - 12 - 20	0 - <u>200 - 300</u> - 500
E856CP1 E856CP2		0 - 10 - 20	0 - <u>200 - 300</u> - 500
E856EP1 E856EP2		minus 5 - 0 - 5	0 - <u>2000 - 3000</u>
Note - Normal range of load resistance values is chosen with underlining			

1.2.2 Limits of the intrinsic error are $\pm 0,5\%$ of the fiducial value.
Upper value of output signal range is taken as a fiducial value.

1.2.3 Variations from influencing magnitudes correspond to table 2.

Table 2

Name of influencing magnitude	Value of influencing magnitude	Variation, % of the fiducial value
Ambient Air Temperature	- 30 to 50 °C	$\pm 0,4$ on 10 °C of temperature variation
Relative Humidity	to 95% at 35 °C	$\pm 0,5$
External magnetic field by strength	to 400 A/m	$\pm 0,5$
Load resistance E856A, E856AP, E856EP	0 to 2000 Ω	$\pm 0,25$
E856B, E856C, E856BP, E856CP	0 to 200 Ω ; above 300 to 500 Ω incl.	$\pm 0,25$
Power Supply	187 to 242 V	$\pm 0,25$

1.2.4 Setup time of performance is 15 min.

1.2.5 Setting time of output signal is 0,5 s.

1.2.6 Ripple amplitude is no more than 0,25 %.

1.2.7 The transducer satisfies the requirements 1.2.2:

- on expiring a setup time of performance;
- at grounding one of output contacts;
- after effecting sine-wave vibrations in a frequency band from 10 up to 55 Hz with displacement amplitude 0,15 mm when transducer is mounted on the rail;
- after effecting sine-wave vibrations in a frequency band from 10 up to 55 Hz with displacement amplitude 0,35 mm when transducer is mounted on the panel.

1.2.8 Transducer withstands a long-lived break of a load circuit without failures. An output voltage at a break of a load circuit is no more than 30 V.

1.2.9 Transducer withstands 120% overload by an input signal during 2 hours.

1.2.10 Transducer withstands tenfold overload by input signal during 30 s.

1.2.11 Isolation between electrical circuits and case, input and supply, input and output circuits withstands a testing voltage of practically sine-wave shape by frequency from 45 up to 65 Hz during 1 min:

- 4 kV RMS - in standard conditions;
- 2,5 kV RMS - to 95% R.H. at 35°C.

Isolation between output circuits and supply withstands a testing voltage of practically sine-wave shape by frequency from 45 up to 65 Hz during 1 min:

- 2 kV RMS - in standard conditions;
- 1,5 kV RMS - to 95% R.H. at 35°C.

1.2.12 Isolation between different outputs of transducer with two outputs withstands a testing voltage of practically sine-wave shape by frequency from 45 up to 65 Hz during 1 min:

- 0,5 kV RMS - in standard conditions;
- 0,3 kV RMS - to 95% R.H. at 35°C.

1.2.13 Electrical insulation resistance of circuits pointed in 1.2.11, 1.2.12 is not less:

- 40 MΩ - in standard conditions;
- 10 MΩ - to 80% R.H. at 50°C;
- 2 MΩ - to 95% R.H. at 35°C.

1.2.14 Input Power Consumption is no more 10^{-6} W.

1.2.15 Power Supply Consumption is no more:

- E856A1, E856AP1, E856EP1 2 V·A;
- E856A2, E856AP2, E856EP2 3 V·A;
- E856B1, E856C1, E856BP1, E856CP1 4 V·A;
- E856B2, E856C2, E856BP2, E856CP2 5 V·A.

1.2.16 Overall dimensions: 120x80x77 mm.

1.2.17 Weight is no more 0,5 kg.

1.3 Construction

General Form of transducer is presented in Annex A.

Transducer has the following parts:

- Case;
- Cover;
- Input stage board;
- Output stage board (one or two)
- Supply transformer;
- Latch.

The contacts established on a cover ensure strengthening the input stage board and reliable contact of conductors of a plated circuit to bringing wires.

The electrical connection of an output stage board with the input stage board is manufactured by the soldering.

The cover is mounted to a case through four screws, which can be sealed up.

The latch ensures mounting the transducer to the rail or panel depending on variant of installation.

1.4 Functional description

The transducer falls into the devices with digital processing of a signal.

Transducer Block Diagram is presented in Figure 1.

Main parts of the transducer are input stage and output stages.

The galvanic isolation between input stage and output stages is ensured with optocouplers and power supply from separate secondary windings of the network transformer.

The input stage is analog-digital converter (ADC) implementing function of sigma-delta transformation.

The fundamental elements of ADC analog part are: an analog Bessel filter of the third degree fulfilling function of a scaling amplifier also; an integrator; a gated analog comparator included into the composition of a microcontroller; the analog switch, which functions is executed by CMOS-structure of microcontroller's output port.

The average on-off time ratio of pulses on an output of the analog comparator is proportional to an input voltage of the transducer.

The fundamental elements of ADC digital part are: the software implemented digital filter LPF; the decimator D; the parallel-to-series converter (P/S).

The codes N_H and N_L arrive at the filter's input synchronously with switching the switch SW1. If time constant of the filter is much greater than a period of a gating T_c , the filter output code is defined by expression

$$N_F = N_L + Q_S \cdot (N_H - N_L),$$

where Q_S is average on-off time ratio of pulses on a comparator output during measurement.

$N_F = 0$ for an initial value of variation of an input voltage range;

$N_F = 2^{11} - 1$ for a finite value of variation of an input voltage range.

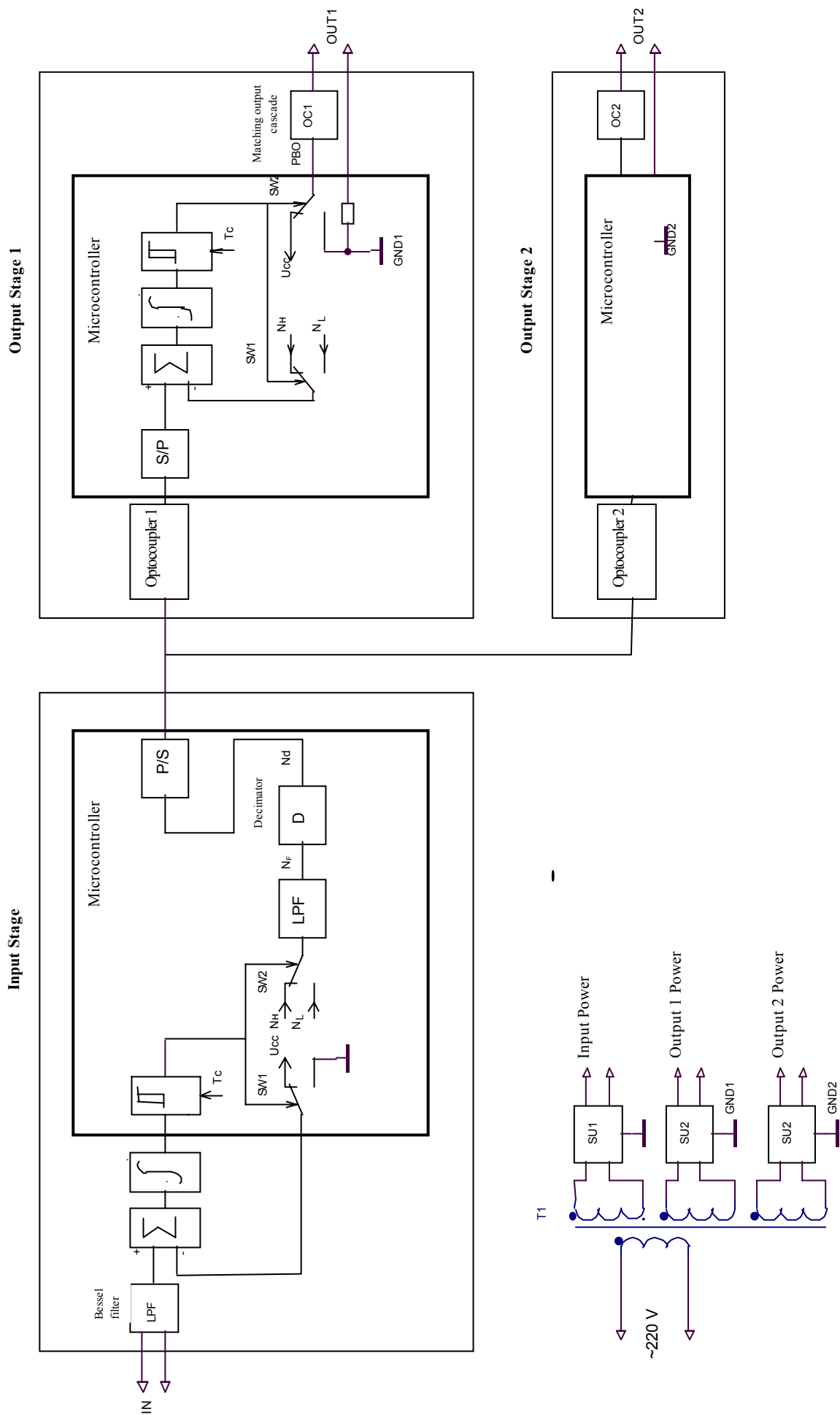

Figure 1. Block Diagram

The output code of the filter arrives to the decimator D. The code accumulates and averages particular quantity of the values which have arrived at its input:

$$N_d = \frac{\sum_{i=0}^{K_d} N_{Fi}}{K_d}.$$

The number of accumulates values K_d is selected by such that following condition was executed:

$$K_d \cdot T_c = 1/50 \quad [1/\text{Hz}],$$

Thus the supply frequency and its harmonics are eliminated from the output signal of a decimator.

The signal from an output of a decimator D is converted to a serial code and transited through the optocoupler to output stages of the transducer.

The output stage is digital-analog converter (ADC) which is carried out by a principle of sigma-delta transformation. It implements function of ADC of input cascade backward.

DAC-digital part of the output stage is software implemented on a microcontroller and includes the following clusters: the series-to-parallel conversion (S/P); an adder; an integrator; a comparator.

DAC-analog part of the output stage includes: CMOS-structure of an output port of a microcontroller; the matching output cascade realized by operational amplifier. The matching output cascade ensures flattening and linear converting of a voltage U_{PBO} on an output of the microcontroller to an output current, that is

$$I_{out} \sim \frac{1}{T_{meas}} \int_0^{T_{meas}} U_{PBO} dt,$$

where T_{meas} is measuring time.

The on-off time ratio of pulses on the comparator output, consequently on an output PBO of a microcontroller, is featured by expression:

$$Q = \frac{N_{in} - N_L}{N_H - N_L},$$

where N_H and N_L are output stage's coefficients.

The mean of voltage on the PBO output is proportional to on-off time ratio of pulses (Q_s):

$$U_{PBO} = U_c \cdot Q_s,$$

where U_c is supply voltage of a microcontroller.

The expression for an output current has an aspect:

$$I_{out} \sim \frac{U_c}{T_{meas}} \int_0^{T_{meas}} [(N_{in} - N_L) / (N_H - N_L)] dt.$$

The coefficients N_H and N_L are erected so that the value of an output current of the transducer was equaled:

- initial value of a range if $N_{in} = 0$;
- finite value of a range if $N_{in} = 2^{11} - 1$.

The precision circuits are applied to stabilize a supply voltage of microcontrollers' input and output stages of the transducer.

The tuning of the transducer is carried on by an electronic mode through a technological connector.

1.5 Marking and sealing

1.5.1 The following information is marked on a cover of the transducer:

- The name and type designation;
- Trade mark of the manufacturer;
- The nominal value of auxiliary supply voltage and nominal value of auxiliary supply frequency;
- maximal value of power supply (VA);
- Input and output signal rated;
- Unit symbol of input and output signals;
- Load resistance range;
- Testing voltage designation of a metering circuit isolation in relation to a body;
- Module of intrinsic error;
- Designation of numbers and polarity of contacts;
- Symbol F-33 ГOCT 30012.1ж
- Serial number and two last digits of Issue Year.

1.5.2 Sealing of the transducer is yielded with a bitumen mastic №1 (according to ГOCT 18680-73) applies on one of four located on a cover screws.

1.6 Packing

1.6.1 The transducers are delivered in transport container.

1.6.2 In transport container there is:

- Operation manual (1 copy on everyone 50 transducers or on separate delivering);
- Packing leaf.

1.6.3 The transducer is packaged into individual packing.

The passport is inserted inside the individual packing.

2 Uses to assignment

2.1 Operational constraints

2.1.1 The transducers are not intended for operation in requirements explosion-hazard and hostile environment.

2.1.2 The transducers must not be effected by direct heat up to temperature more 50°C. The transducers should be placed on the premises without sharp temperature fluctuation and off the sources of strong electromagnetic field.

2.2 Preparation for use

2.2.1 Check the integrity of packing after deriving the transducer. Unpack it. Take out the transducer, make exterior survey, get sure that any apparent mechanical damages are missing. Check completeness of delivering according to table 3.

Table 3

Name and nomenclature	Designation	Quantity
Transducer	49501860.3.0004	1
Direct current measuring transducers E856A, E856B, E856C, E856AP, E856BP, E856CP, E856EP. Operation manual	49501860.3.0004 PЭ	1 экз*
Direct current measuring transducer E856A (E856B, E856C, E856AP, E856BP, E856CP, E856EP). Passport	49501860.3.0004 ПС	1
Individual package		1
Latch		1**
* On a batch in quantity 50 pieces, delivered at the one address		
** Set on the case		

2.2.2 Check the information on a cover of the transducer on correspondence to required parameters.

2.3 Use

2.3.1 All operations on mounting and maintenance should be making with observance of live rules on provision of safe service.

2.3.2 Make arranging a place of mounting of the transducer on plant according to an Annex B.

2.3.3 Installation of the transducer on plant

2.3.3.1 When mounting the transducer *on the rail*:

- place a latch according to figure B.1 to link the protuberances of a case to edge of the rail;
- push a case up to its fixing.

The mounting of the transducer on the rail is supposed at mount the rail on a horizontal or vertical plane.

When the rail is mounted on the vertical plane, its distortion from a horizontal position should not be more than 15°.

2.3.3.2 When mounting the transducer *on the panel*:

- fix a latch on the panel with the help of two screws according to figure B.2;

- pull the transducer over a latch against the stop.

Use two screws with a diameter 4 mm to fasten a latch on the panel. Screws should not overhang a mounting plane of the latch.

When mounting the transducer on a latch is necessary to provide on object a place not less than 15 mm for initial fixing of the transducer.

2.3.4 Fix exterior conductive wires on contacts according to the connection diagram, which is located in the Annex C.

2.3.5 Verify the correspondence of output parameters of a radiant of a signal to data-ins of the transducer. Verify quality of wiring.

2.3.6 Turn on supply voltage 220 V on the transducer.

2.3.7 Turn on an input signals on the transducer.

2.4 Operation in extreme conditions

2.4.1 You should turn out the transducer in case of originating an emergency condition of operation immediately.

3 Maintenance and repair

3.1 Generalities

3.1.1 The operational supervision of operation of transducers should be manufactured by faces which have the responsibility for this equipment.

3.1.2 The transducer having a warranty seal of the manufacturer should not be opened during operation.

3.1.3 The manufacturer eliminates all defects originating during operation.

3.2 Safety

3.2.1 The qualified personnel should execute operations of maintenance.

3.2.2 The transducers correspond to ГОСТ Р 52319-2005 (МЭК61010-1:2001).

Insulation class is primary. Pollution degree is 2. Overvoltage category is III.

Measuring circuits: CAT III 600V; CAT II 1000 V.

3.2.3 IT IS FORBIDDEN: TO CHANGE EXTERNAL CONNECTIONS, WHEN INPUT SIGNAL AND SUPPLY VOLTAGE ARE AVAILABLE IN THE TRANSDUCER.

3.3 Order of maintenance

3.3.1 It is recommended quarterly to carry out routine inspection in field. For this purpose:

- to turn input signal and supply voltage off;

- to delete from a case a dust;

- to test a condition of a case; to be convinced of absence of mechanical failures; to test a condition of mounting;

- to turn a supply voltage and input signal on the transducer after the termination of survey on.

3.3.2 If the transducer is mounted on the rail you can carry demounting by release of a latch by a screwdriver inserted into a recess in the bottom of the case.

3.4 Metrology monitoring

3.4.1 To confirm real values of the metrology characteristics and fitness of the transducer to application, they can be exposed to calibration according to the document 49501860.3.0004 МП «Преобразователи измерительные постоянного тока E856A, E856B, E856C, E856AP, E856BP, E856CP, E856EP. Методика поверки» («Direct Current Measuring Transducers E856A, E856B, E856C, E856AP, E856BP, E856CP, E856EP. Calibration procedure») which was matched with ВНИИМС (All-Russian Research Institute).

The transducer should be calibrated on a 1-year interval determined by the requirements of this document.

4 Storage

4.1 Before introduction in operation the transducers should be stored in storehouses according to ГOCT 12997-84.

4.2 Storage conditions for transducers in transport container:

- Ambient Air Temperature 5 to 50 °C;
- Relative Humidity at 25 °C up to 80 %;

4.3 Storage conditions for transducers in individual packing:

- Ambient Air Temperature 10 to 35 °C;
- Relative Humidity at 25 °C up to 80 %;

4.4 The contents of a dust, steams of acids and alkalis, aggressive gases and other harmful admixtures calling corrosion should not exceed the contents of the corrosion-active agents for the atmosphere of a type 1 (ГOCT 15150-69).

5 Transportation

5.1 The transducers in transport container can be transported in the closed vehicles of any type. When air transportation the transducers should be disposed in heated hermetic bays.

5.2 Values of climatic and mechanical effects on the transducer at transportation should be in limits:

- Ambient Air Temperature - 50 to 50 °C;
- Relative Humidity at 35 °C up to 95 %;
- Atmospheric pressure, kPa (mm Hg) 84-106 (630-800).
- Impacts with peak shock acceleration 98 m/sec².

Annex A
(informative)
General Form of the transducer

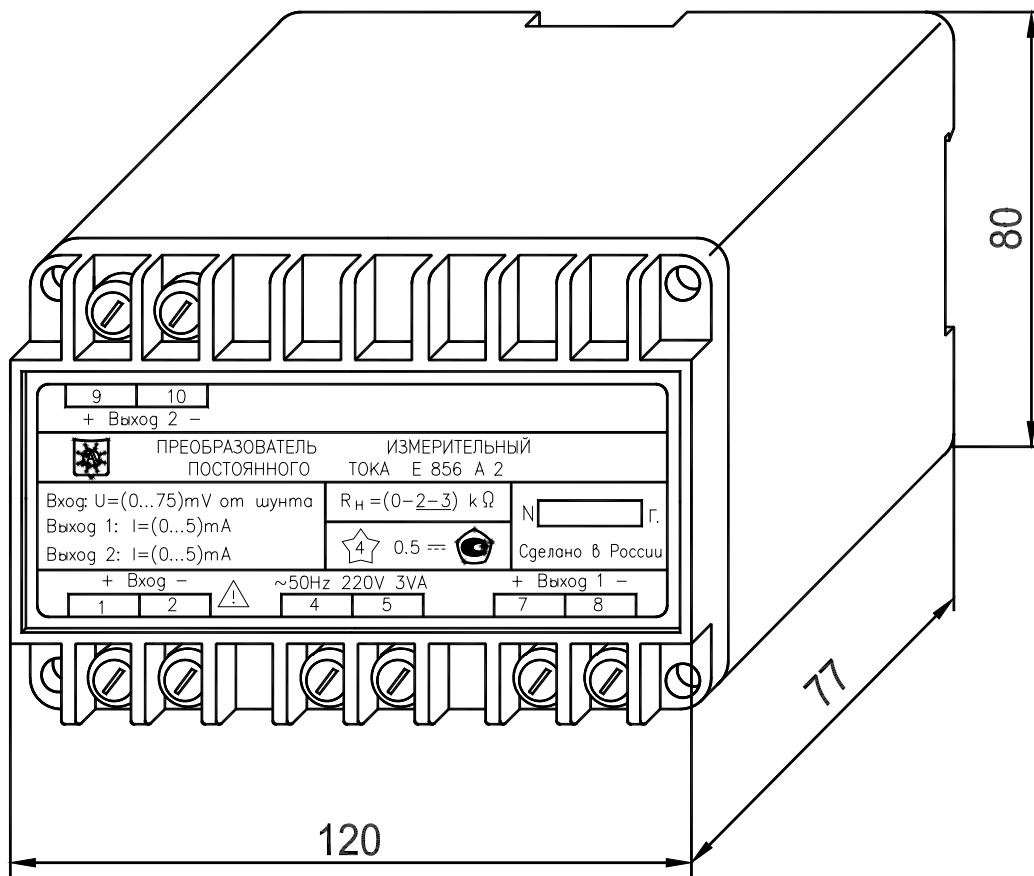

Figure A.1

Annex B
(informative)
Variants of transducer mounting

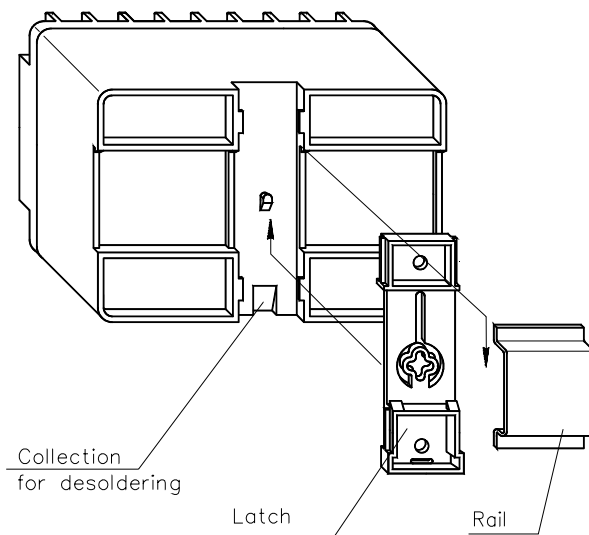

Figure B.1 Mounting on the Rail

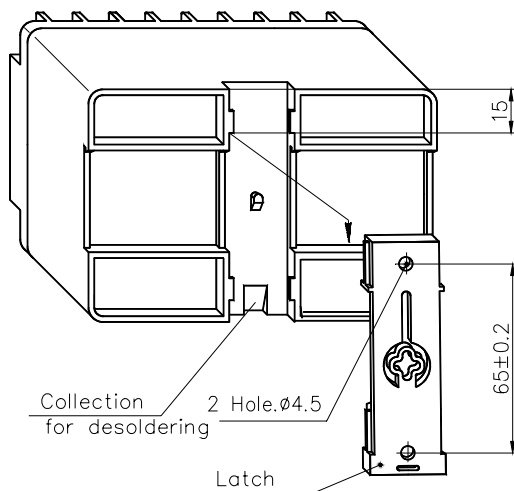
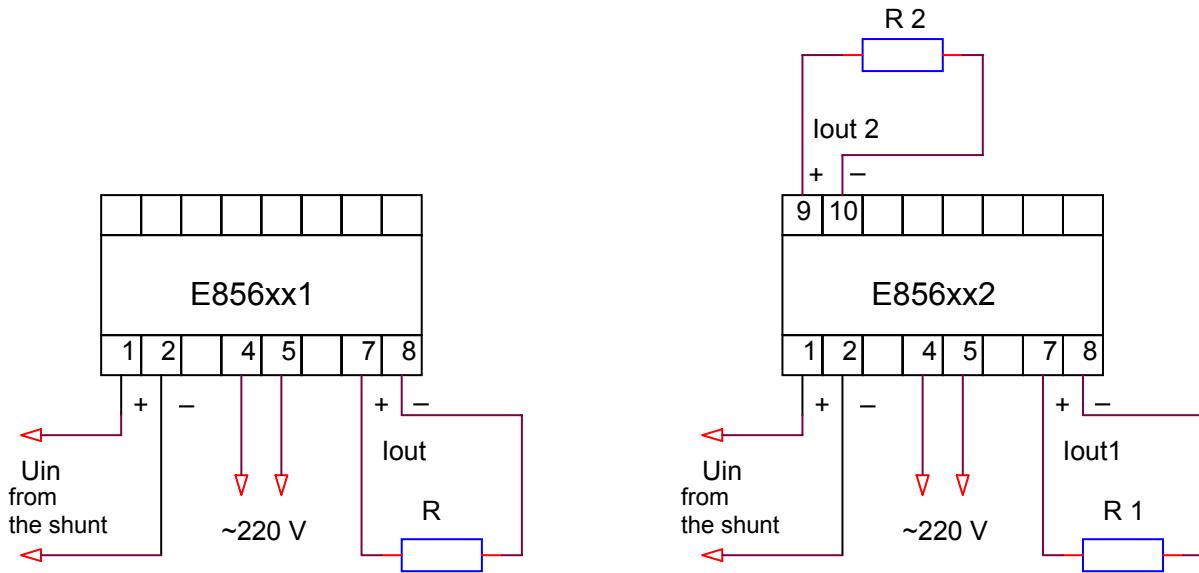

Figure B.2 Mounting on the Panel

Annex C
(informative)
Diagram of transducer connections



- a) E856A1
 E856B1
 E856C1
 E856AP1
 E856BP1
 E856CP1
 E856EP1

- b) E856A2
 E856B2
 E856C2
 E856AP2
 E856BP2
 E856CP2
 E856EP2

Figure C.1